

A Multimedia-based Approach to Teaching Engineering Drawing

Kuang, J. S. ¹ and Hu, Thomas W. C. ²

¹ cejkuang@ust.hk

² thomashu@ust.hk

Department of Civil Engineering,
Hong Kong University of Science and Technology

INTRODUCTION

- CIVL 114: Civil Engineering Drawing
- Similar courses offered by civil / building / construction engineering, etc. at various university & technical schools
- Emphasis on CAD
- Typical learning difficulties:
 1. CAD software operation
 2. Interpretation of construction drawings

1. Teaching CAD:

- Traditional approach: software demo given in ITSC computer barns with detailed notes
- Students may still miss a step or two, and then fail to follow all the rest
- A common problem when teaching how to use a software
- Repeating demo for some students may slow down the others
- Sample teaching material (text and graphics):

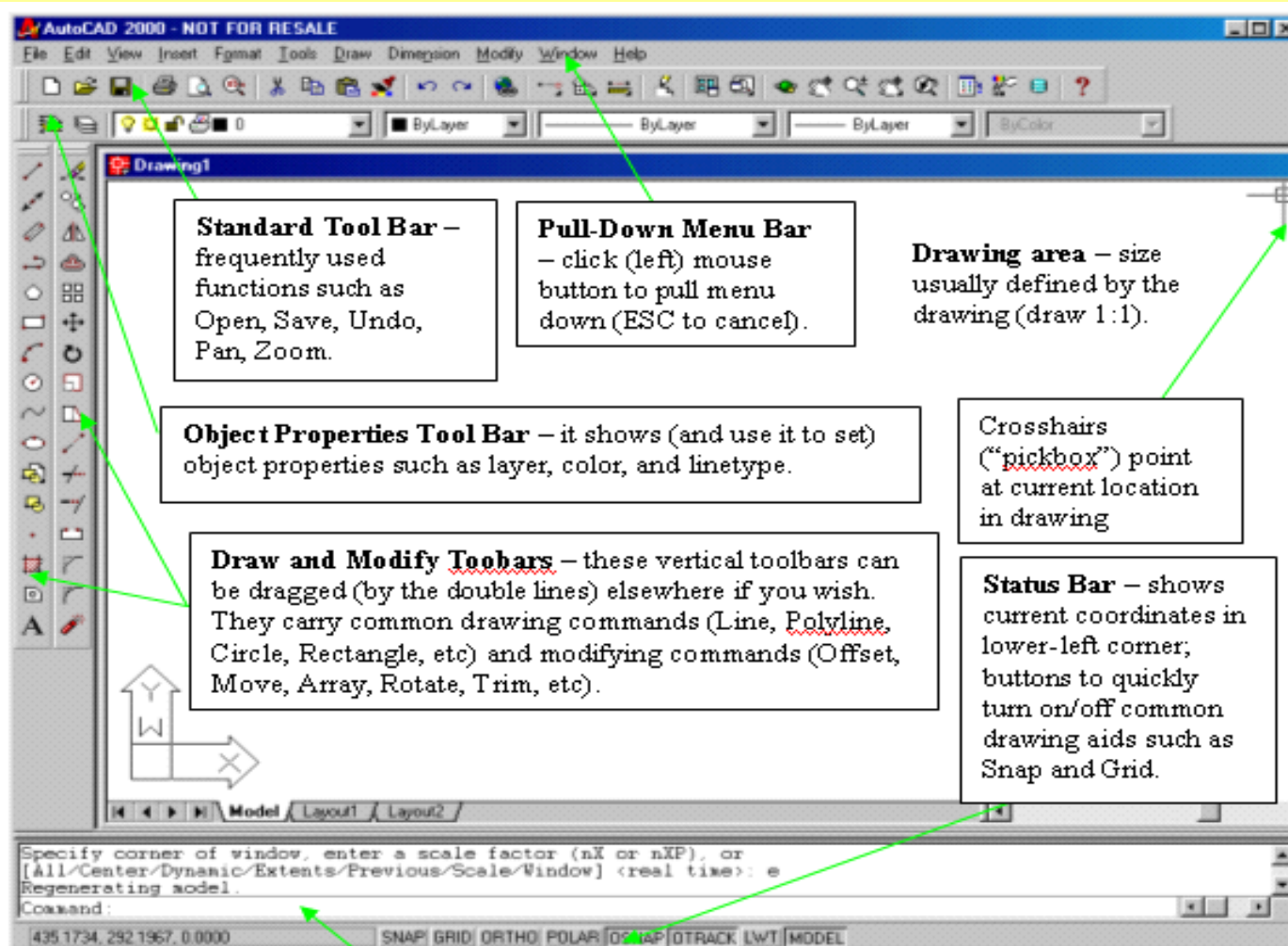

Command window – enter commands here to communicate with ACAD; 3 command lines are seen by default. Press F2 to see more lines / go back to drawing window.

The following AutoCAD commands can be used to determine the coordinates of C:

1. Use POINT command (or *Draw – Point – Multiple Points*) to draw points A and B at their given coordinates. Exit POINT command, and Z(oom) – E(xtent) to see the 2 points drawn. If the default point style is too small to see, you can use *Format – Point Style* – (choose “X” type) to fix it.
2. Right-click “OSNAP” tab at screen’s bottom, click Settings, and turn on the “Node” (NOD) and “Intersection” (INT) object snap option. The NOD option allows one to snap to a point.
3. Draw a LINE from points A to B using object snap.
4. Use ROtate (or *Modify – Rotate*) to rotate AB by $49^{\circ}27'18''$ into the direction of AC. Pick line AB when prompted to *select objects*, press *enter*, use A as *base point*, and give a *rotation angle* of – **49D27'18"**. Note that AutoCAD takes counterclockwise angles as positive by default, and accepts the D/’/” format when specifying angles.
5. Redraw the line AB, then rotate it by $37^{\circ}14'36''$ about base point B. Draw the line AB again.
6. Use ID to find out the coordinates of the INTersection point of the two lines on the screen.
7. From pull-down menu, *Dimension – Style – Modify* – (click *Primary Units* Tab) – change Angular Dimensions to D/M/S format with 0.1” accuracy – *OK – Close*.
8. *Dimension – Angular*, pick two lines to have AutoCAD calculate and label the angles between them. If the text is too small, set DIMSCALE to a new value (e.g. 1.5), and *Dimension – Update* – select dimension(s) to update. This will double-check the correctness of the angles input.

- Printed material + live demonstrations may not be the most efficient approach
- Better way to explain software use: screen-capture movies
- On-screen tips, voice, callouts, etc. can be added after video capture
- Examples:



Pick this line by mouse

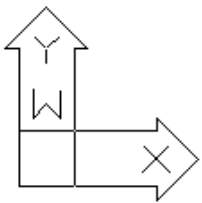
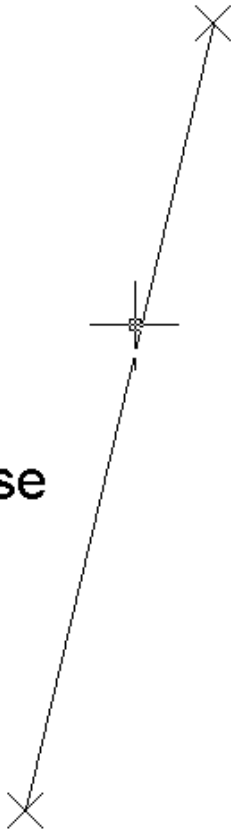

Command: *Cancel*
Command: *Cancel*
Command:

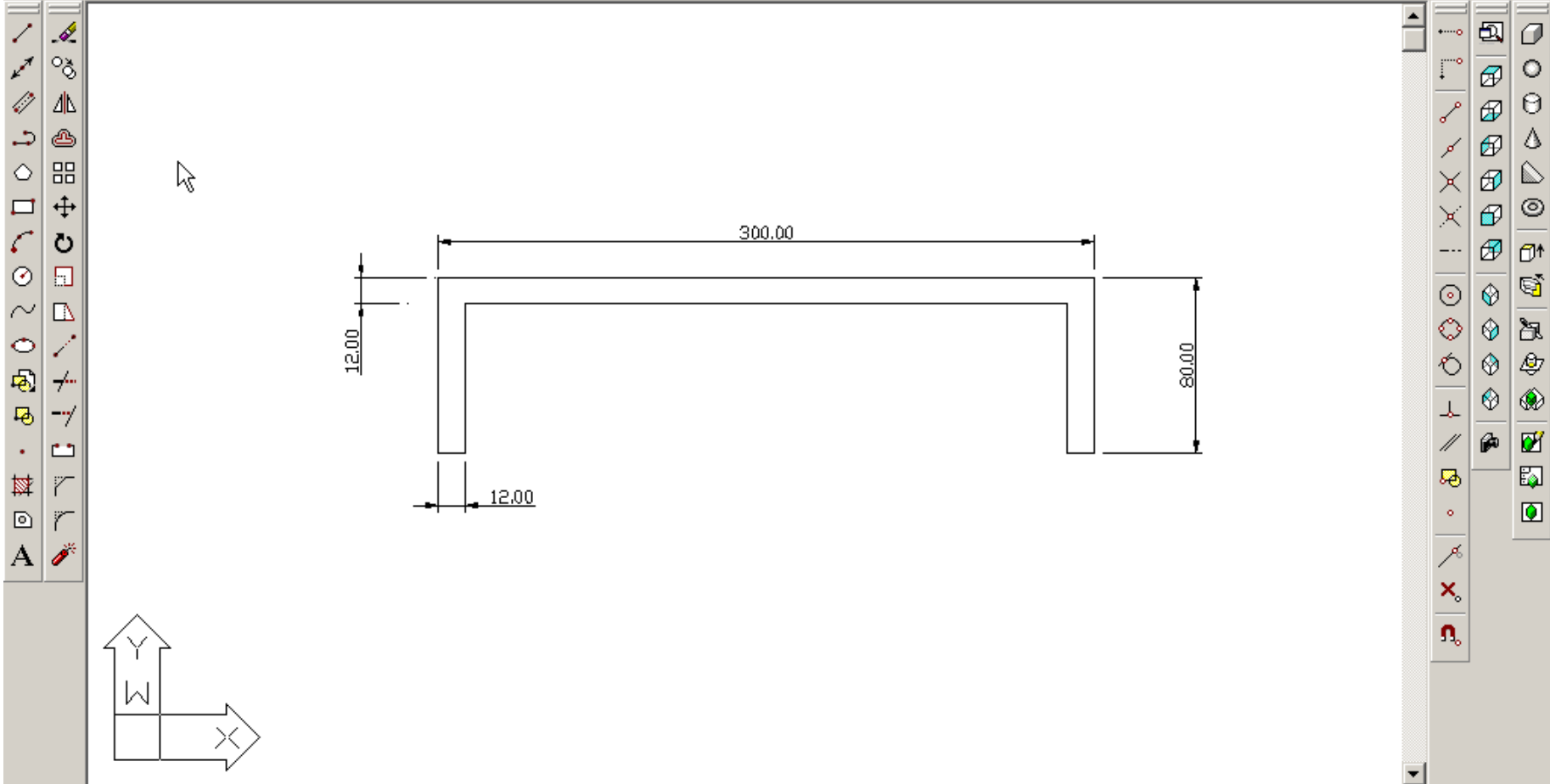
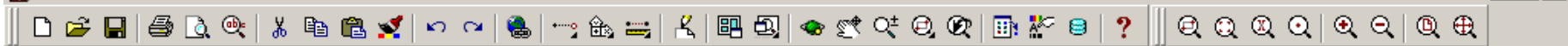

Select objects: Specify base point or displacement: Specify second point of displacement or <use first point as displacement>:

Command:

Advantages :

- Can be viewed at student's own pace and repeated as many times as needed
- Available for learning or revision beyond the classroom
- Indispensable tool when class attendance is not possible
- Useful for any software-related class

2. Understanding Drawings

- Traditionally: construction drawings often presented in 2-D (plan, section and elevation)
- Special nomenclature adopted on construction drawings
- “Use your imagination”: students may experience difficulties connecting various views mentally
- Sample drawing:

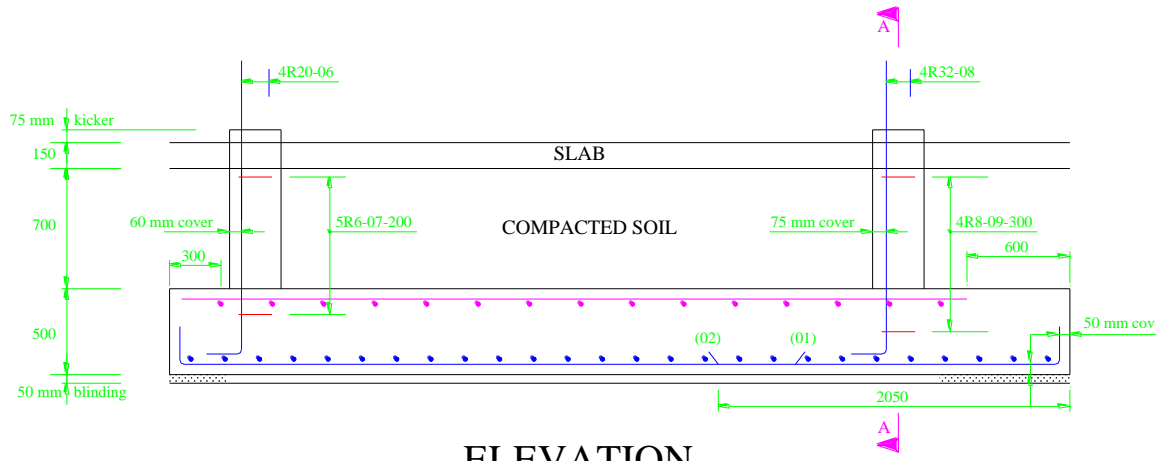

ELEVATION

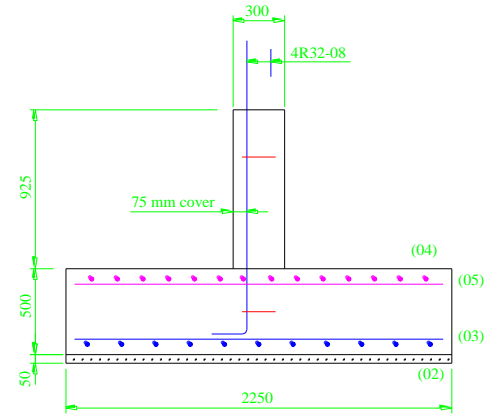

A-A

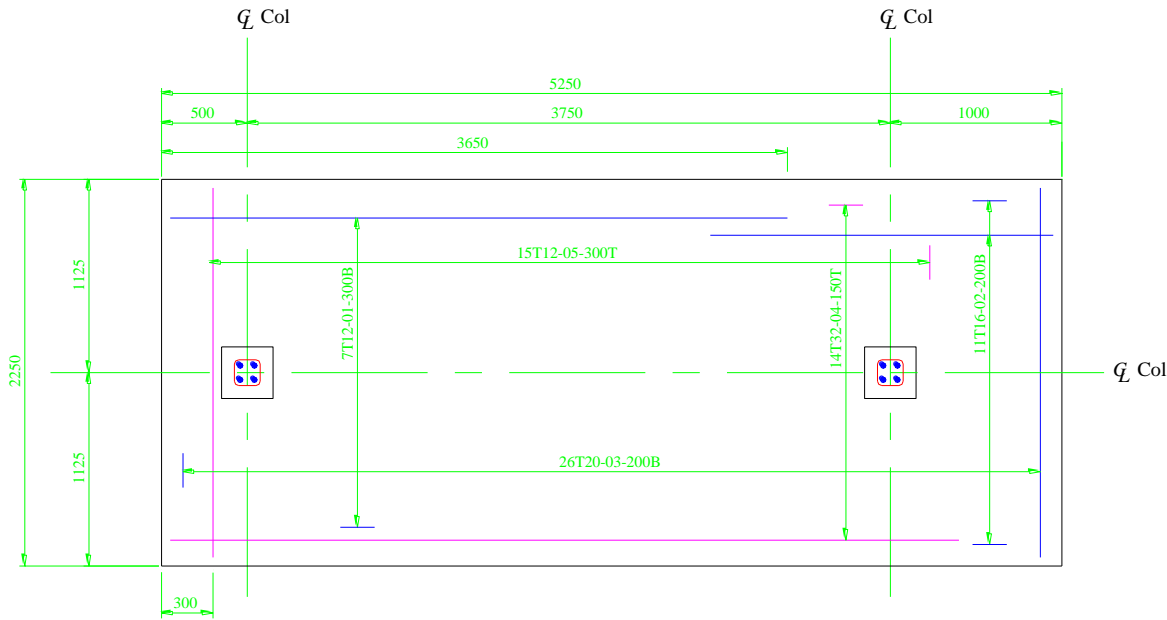

PLAN

**BASE TYPE 2
8 No. THUS**

Using 3-D animation to supplement 2-D material:

In previous example:

- Mainly 5 sets of rebars ("01" to "05")
- Sets 04 and 05 are on top ("T")
- Sets 01, 02 and 03 at the bottom ("B")
- Animate the bottom bars with emphasis on bars marked "02" (say)

Sample video (to explain "02" bars):

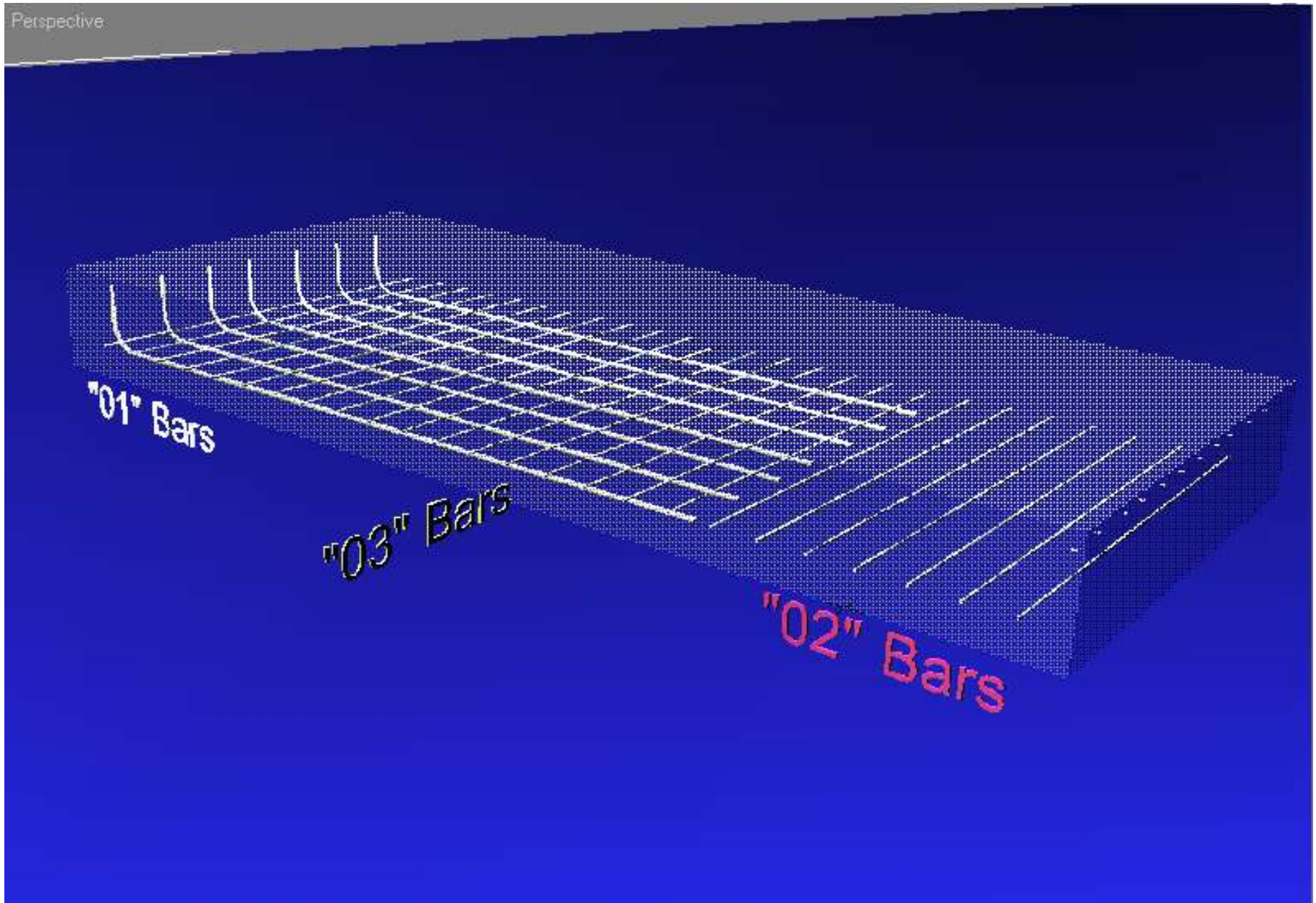

Advantages:

- Vivid visualization without “using your imagination” alone
- May control flight path of camera going from one view to another
- Rendered into AVI files
- Facilitates self-study after class

Putting everything together:

- A more web-based drawing course
- AVI files to explain software operation
- 2-D drawings prepared with Flash: user may click on various parts in doubt to see explanatory 3-D animation
- An on-going CLI project

The background is a vertical gradient of blue. At the top, there are wispy white clouds. On the left side, a bright sun is partially visible, creating a shimmering reflection on the surface below. The overall effect is a serene, oceanic scene.

Thank you